



I.O.B.C.
international.open.baja.cup.



04-07. August 2022

SUPPLEMENTARY REGULATION

Visa nr:

MAMS: MAMS/066/2022

EMN: 34/310

IMN: 814/05

CONTENTS:

INTRODUCTION	3
PROGRAMME	3
1.DESCRPTION	4
2.ORGANIZER	6
3.ENTRIES	7
4.INSURANCE	8
5.ADVERTISING	8
6.IDENTIFICATIONS	8
7.TYRES	8
8.FUEL	8
9.ADMINISTRATIVE CHECKS	9
10.TECHNICAL SCRUTINEERING, SEALING AND MARKING	9
11.QUALIFYING STAGE	9
12.START OF THE EVENT	10
13.RUNNING OF THE EVENT	10
14.SERVICEPARK	11
15.PROTEST AND APPEALS	11
16.FINAL CHECKS	11
17.RESULTS	11
18.PRIZES	12

Appendix 1_Timetable

Appendix 2_Relations crew officer

Appendix 3_ Instruction for the use of the Tracking System

HUNGARIAN BAJA is organised by **Garilla Racing Kft.** and **Garzone s.r.o** on 04-07. 08. 2022.

The race has the following regulations, which will apply to all drivers and competitors signing the entry form:

- MAMS International Open Baja Championship regulations
- Traffic Regulations Hungary
- The present Supplementary Regulations and its appendices,
- Official bulletins

OFFICIAL LOCATIONS		
REGISTRATION	SUZUKI MÉSZÁROS 8100. Várpalota, Grábler Tó str. 10.	N47°11'58 E18°19'13
SERVICE	GÁL GYULA SPORS HALL parking lot 8100. Várpalota, Fehérvári str. 9.	N 47°11'59.4132" E 18°8'48.7926"
SCRUTINEERING	SUZUKI MÉSZÁROS 8100. Várpalota, Grábler Tó str. 10.	N47°11'58 E18°19'13
RACE OFFICE / HQ	THURY CASTLE 8100. Várpalota, Hunyadi Mátyás Tér 1.	N47°12'05 E18°08'20
PARC FERMÉ	FŐTÉR 8100. Várpalota, Szabadság Tér	N47°11'58 E18°08'26

PROGRAMME				
	LOCATION:	DATE:	TIME:	
Publishing of the supplementary regulations	www.hungarianbaja.com			
Entries open	Garilla Racing Kft. 8200 Veszprém, Házgyári str. 1. +36307914270 info@hungarianbaja.com www.hungarianbaja.com	01.06.2022.	10:00	
Organiser's office opening				
Media Accreditation Start				
Issuing of Rally Guide			11.07.2022	24:00
Closure date of entries with reduced fees			25.07.2022	20:00
Closure date of entries			27.07.2022	10:00
Closing date for order of extra service in SP		Thury Castle, Várpalota		16:00
Pre Event Press conference	Thury Castle, Várpalota	27.07.2022		
Publication date of entry list	www.hungarianbaja.com			
Registration, Check List and Service Plate delivery	Suzuki Mészáros, Grábler Tó str. 10.	04.08.2022	12:00-21:00	
Service Park Opening	GÁL GYULA SPORS HALL parking lot 8100. Várpalota, Fehérvári str. 9.			
Registration, Check List and Service Plate delivery	Suzuki Mészáros, Grábler Tó str. 10.	05.08.2022	06:00	
Service Park Re-Opening	GÁL GYULA SPORS HALL parking lot 8100. Várpalota, Fehérvári str. 9.			
Collection of rally safety tracking system	Rally Office, Thury Castle		07:00-12:00	
Administrative Check			07:30-12:30	
Scrutineering – sealing & marking of components	Suzuki Mészáros, Grábler Tó str. 10.		08:00	
Opening of media centre	Rally Office, Thury Castle		07:00	
HQ Opening			12:00-15:00	
Entry to the Parc Fermé- Start Area	Várpalota Főtér, Szabadság Tér		15:15	
Press Conference before the Baja	Thury Castle, Várpalota			

Team managers and/or Drivers' briefing / Issuing of the road book, maps	Thury Castle, Várpalota	05.08.2022	15:45
Publication of list of b/q eligible to start	Digital Notice Board		
Publication of start list for Leg 1			
Start of the Rally – Leg 1, Section 1	Várpalota Főtér, Szabadság Tér		16:45
Publication of provisional classification of QS	Digital Notice Board		19:45
Publication of final classification of QS			20:30
Ceremonial Start	Várpalota Főtér, Szabadság Tér		20:00
Finish of Leg 1, Section 1 (estimated time of 1st bike)	Várpalota		20:30
Publication of the Results Leg 1, Section 1	Digital Notice Board		21:00
Publication of start list for Leg 1, Section 2			
Closing date for the HQ	Thury Castle, Várpalota		
HQ Opening	Thury Castle, Várpalota		06.08.2022
Opening of media centre			
Start of Leg 1, Section 2		08:10	
Finish of Leg 1 (estimated time of 1st bike)		16:45	
Publication of Results Leg 1.	Digital Notice Board		18:30
Publication of start list for Leg 2, Section 4			
Closing date for the HQ	Thury Castle, Várpalota		19:00
HQ Opening	Thury Castle, Várpalota	07.08.2022	07:00
Opening of media centre			
Start Leg 2, Section 4			08:15
Finish of Leg 2 (estimated time of 1st bike)			13:25
Final scrutineering (following the marshals' instructions)			Immediate after arrival in the finish
Publication of Provisional Classification			15:30
Publication of Final Classification	Digital Notice Board		After the Jury have declared the Classification final.
Prize-giving Celebrating Podiums Ceremony	Várpalota Főtér, Szabadság Tér		16:00

1. DESCRIPCION

1.1 PLACE AND DATE OF THE EVENT:

HUNGARIAN BAJA is taking place in Várpalota surroundings, county Veszprém, Hungary, on 4-7 august, 2022.

1.2 TITLES FOR WHICH THE HunGarian Baja COUNTS:

FIM Bajas Word Cup and International Open Baja Cup (2022)

MAMS International Open Baja Cup, with International Participants

1.3 VISA NR:

MAMS Nr: MAMS/066/2022

EMN Nr: 34/310

IMN Nr: 814/05

1.4 LOCATION OF BAJA OFFICE:

From **01.06.2022** GARILLA RACING KFT.
H- 8200 Veszprém, Házgyári str.1.
Tel: +36-30-791-4270
e-mail: info@hungarianbaja.com
web: www.hungarianbaja.com

From **03.08.2022** Thury Castle, Hunyadi Mátyás Tér 1., 8100 Várpalota
GPS COORDINATE: N47°12'05 E18°08'20

1.5 START/ FINISH:

LOCATION: FŐTÉR, Szabadság Tér, 8100 Várpalota

1.6 PRESS OFFICE LOCATION:

LOCATION: THURY CASTLE, Hunyadi Mátyás Tér 1., 8100 Várpalota

TIME:

Friday	05. August 2022	08:00-21:00 hrs
Saturday	06. August 2021	07:00-19:00 hrs
Sunday	07. August 2021	08:00-16:00 hrs

1.7 OFFICIAL NOTICE BORD:

Digital Notice Board (DNB): [Sportity](https://www.sportity.com), www.chromoto.hu, www.hungarianbaja.com



On PC: https://webapp.sportity.com/channel/HGB22_MAMS

1.8 SCRUTINEERING (at the scheduled time): SUZUKI MÉSZÁROS, Grábler Tó str.10

1.9 LOCATION PARC FERMÉ:

Várpalota Főtér GPS COORDINATE: N47°11'58, E18°08'26
Szabadság Tér, 8100 Várpalota

1.10 LOCATION SERVICE PARK:

GÁL GYULA SPORS HALL parking lot
8100. Várpalota, Fehérvári str. 9. GPS COORDINATE: N 47°11'59.4132" E 18°8'48.7926"

1.11 SELECTIVE SECTIONS, THE AVERAGE ALTITUDE ABOVE SEA LEVEL:

Leg 1: 283,39 km
Leg 2: 132,52 km

Overall SS distance and total distance of the itinerary

Number of Legs 2
Number of Sections 5
Number of Selective Sections 5
Total distance of the itinerary 565,54 km
Overall length of Selective Sections 415,91 km

The average altitude above sea level of Hungarian Baja's Selective Sections is under 1000 meters.

2. ORGANIZER

2.1 ORGANIZER'S NAME:

Garilla Racing Kft. and Garzone s.r.o.

2.2 ORGANIZER'S ADDRESS AND CONTACT DETAILS:

Garilla Racing Kft.

Responsible for competition: Garamvölgyi Zoltán

info@garzoneracing.com

Phone: +36 30/791-4270

GarZone s.r.o. Vel'koblahovská 75/39, Dunajská Streda

info@garzoneracing.com

2.3 ORGANIZING COMMITTEE:

President of the Organizing Committee: Mr. Zoltán GARAMVÖLGYI
Members of the Organizing Committee: Mr. Sándor NÉMETH
Mr. Ferenc SCHEIBENHOFFER

2.4 OFFICIALS:

Clerk of the course Mr. János FALICS
Deputy of Clerk of the Course: Mr. Richárd KELEMEN
Jury Prezident Mrs. Brigitta VARGA
Chief Scrutineer Mr. Gábor FARKAS
Medical Officer: Dr. Zoltán PÁLL
Safety Officer: Mr. Sándor NÉMETH – Kékfény Security
Head of Secretary: Ms. Julianna TÖRÖK
Secretary to the Jury Mrs. Éva HORVÁTH
Competitors Relation's Officer: Mr. István MÁTRAI
Mrs. Mariann MAGYAR KELEMENNÉ
Press Officer: Mr. Anita TÓTH
Timekeeping Results: ChronoMoto Kft.
GPS Control Results: STELLA
Environmental Officer : Mr. Péter BAKÓ
Responsible for Road Book: Mr. Roland PÁLINKÁS
Responsible for checking the Road Book: Mr. Péter FALUVÉGI

2.6 IDENTIFICATION OF OFFICIALS:

Competitors Relation Officer	“CRO” Pink tabard
Scrutineers	“ATB” Blue tabard or shirt
Post Chiefs:	“VEZETŐBÍRÓ” Red tabard
Special Stage Commanders:	“VEZETŐBÍRÓ” Red tabard
Marshals:	“SAFETY” / “SPORTBÍRÓ” Yellow or White tabard
Timekeepers:	“CHRONOMOTO” Black shirt

3. ENTRIES

3.1 DATES:

OPENING date for ENTRIES:	Tuesday, 01. 06. 2022.	10:00 hrs
CLOSING date for REDUCED ENTRY FEE:	Monday, 11. 07. 2022.	24:00 hrs
CLOSING date for ENTRIES:	Monday, 25. 07. 2022.	20:00 hrs

3.2 ENTRY PROCEDURE:

You can submit your entry on the following website: www.hungarianbaja.com. Signed Entry Forms, together with the proof of transfer payment, and scan copies or pictures of all documents related to Administrative Checks should be sent to the following email address: julianna@garzonercing.com.

3.3 NUMBER OF ENTRIES AND GROUPS:

The number of competitors must be a minimum of 15 vehicles.

Groups: Motor, Quad

3.4 ENTRY FEE, OTHER:

3.4.1. ENTRY FEE

EUR 300	payment transferred up to closing date with reduced entry fee: 11.07.2022
EUR 450	up to entry closing date: 25.07.2022

Without organiser's optional advertising:

EUR 450	payment transferred up to closing date with reduced entry fee: 11.07.2022
EUR 700	up to entry closing date: 25.07.2022

The entry fee includes:

- Additional compulsory liability insurance
- Basic service plate/competing vehicle (1pc)
- Basic service area per vehicle (30m²)

Team Registration: 100€

3.4.2. TO BE PAYED ON SITE!

Deposit for GPS navigation and safety tracking system:	100 €
GPS navigation and safety tracking system STELLA Rental Fee	200 €
GPS navigation and safety tracking system's installation kit :	60 €

For a Service area up to 30m², max 2 entry permission can be purchased! Teams, who want to enter with more vehicles, must purchase an additional 30m² service area. Service areas requested and the number of service vehicles has to be indicated on the Entry Form.

3.4.3. OTHER FEES

- additional permission to the service parc (service plate):	30 €
- Additional service area (30m ²):	30 €
- Trailers, Motorhomes, Promotion Vehicles:	60 €

3.5 PAYMENT METHOD:

Any entry not accompanied by the entry fee shall be null and void.
The entry fee should be transferred to the following bank account(€):

GARZONE s.r.o.: Dunajská Streda, Veľ Koblahovská str. 75/39, Slovenská Sporiteľna, a.s.

Account Nr: 5063476359/0900

IBAN N°: SK2609000000005063476359

SWIFT: GIBASKBX

please note: „ENTRY FEE Hungarian Baja 2022 and Competitors name”

The Application form will be accepted only with the proof of payment of the fee.

Signing the Entry Form, competitors agree that the GPS system operators give their data to the organizer, the event's officials.

4. INSURANCE

Complementary compulsory liability insurance Included in Entry Fee!

5. ADVERTISING

The logos will be published in Bulletin

1 - Three race number panels with compulsory advertising 20 x 20 cm on each side and on the front of the vehicle

2 - One rally plate placed vertically at the front of the vehicle

3 - One race number panel with compulsory advertising 30 x 30 cm to the back of the Riders jacket

4 - Advertising sticker (30x30 cm-can be cut to so that it can be easily affixed)

Compulsory or optional advertising absent or incorrect affixing will entail a penalty of 50% of the entry fees. In case of repeated offence, it will go up to exclusion.

6. IDENTIFICATION

Considering MAMS General Prescription Art.nr.15.

7. TYRES

Considering MAMS General Prescription Art.nr.11.

8. FUEL

Only commercially available fuel can be used, without adding any additives, marked in the Road Book.

On SS2A, SS2B and SS3A, SS3B will be a Neutralization Zone for all Competitors and a separate Remote Refuelling Zone (RRZ) for Motor, Quad, SBS vehicles only.

9. ADMINISTRATIVE CHECK

Before Administrative Check, each vehicle must **Register** at Suzuki Mészáros, Grábler Tó str.10, where the Checklist and Service Plates will be provided.

9.1 LOCATION: THURY CASTLE, Hunyadi Mátyás Tér 1.
GPS COORDINATE: N 47° 5'7" E 17°58'10"

9.2 TIMES SCHEDULE: 05.08.2022 07:00-12:30

The scheduled times for the Administrative and Technical Check for each competitor will be published on the official website www.hungarianbaja.com and communicated to all crews by email on 29.07.2022.

GPS tracking system rental is compulsory before the administrative check.

9.3 DOCUMENTS TO BE PRESENTED:

To minimize the time required for administrative check, please make a photo or scan copies of the documents required, and send them to the following email address: julianna@hungarianbaja.com.

Make sure to bring and present the original of the documents as well:

- Competitor's licence
- Driving licence
- Vehicle's registration document
- Vehicle's compulsory insurance policy
- Starting Permission (who is concerned)
- Authorization (if needed)

10. TECHNICAL SCRUTINEERING, SEALING AND MARKING

10.1 LOCATION: SUZUKI MÉSZÁROS, Gráble Tó str.10.

10.2 TIME: 05.08.2022. 07:30-12:30

The scheduled times for the Administrative and Technical Check for each competitor will be published on the official website www.hungarianbaja.com and communicated to all crews by email on 29.07.2022.

Competitors has to present for technical scrutineering with their helmets!

10.3 REQUIREMENTS AT TECHNICAL SCRUTINEERING:

- Vehicles must be presented with all start numbers, rally plates, and advertisements fixed properly on the designated place.
- Tracking equipment and inter-vehicle signalling system installed and operable even when the ignition removed, it is compulsory to provide 12V
- Scrutineering Sheet- filled up

10.4 PARC FERMÉ:

Following the technical scrutineering, each vehicle must be set in Parc Fermé up to 15:00.

Location: FÓTÉR, Szabadság Tér

10.5 SAFETY REQUIREMENTS:

All competitors are obliged to use a GPS Navigation and Safety Tracking System (STELLA), to buy the installation kit if is necessary before the Administrative Check. Returning the GPS and collecting the deposit: at the Parc Fermé to the STELLA crew.

The instruction for the use of the Tracking System is in the Appendix 3. of these Supplementary Regulation.

11. QUALIFYING STAGE

TIME: 05.08.2022. 16:45

12. START OF THE EVENT

12.1 PARC FERME BEFORE THE OFFICIAL START:

LOCATION: FŐTÉR, Szabadság Tér

DATE: 05.08.2022. 12:00-15:00

12.2 BRIEFING (COMPULSORY)

LOCATION: THURY CASTLE, Hunyadi Mátyás Tér 1.

DATE: 05.08.2025. 15:45

12.3 PUBLICATION OF START LIST AND STARTING POSITION:

On Digital Notice Board, according to the programme above.

12.4 OFFICIAL START:

According to the programme above.

13. RUNNING OF THE EVENT

13.1 ROAD BOOK PROVIDING

Road Book delivery will be at Briefing.

13.2 TIME CARD PROVIDING/EXCHANGES

Time cards will be issued before the Start of each Leg, which must be submitted to the marshalls at the Finish of each Leg. The time card must be filled up by the competitor as instructed by the marshalls.

Time card exchanging: at regrouping.

13.3 LIMITED TIME DELAY

Maximum delay between two TC is 30 minutes per Leg. Delay exceeding this limit will result in disqualification.

13.4 FIXED PENALTY

Competitors who got fixed penalties on the day of the race, can revert to the race- at regrouping areas and parc –fermé at the end of the day, until the first vehicle's planned time, in compliance with the other rules described in the TROB Regulations. The Timecard and Time schedule contains the maximal times at the selective stages.

13.5 EARLY CHECK IN AT THE END OF LEG:

At TC1E, TC3C, TC5C, Parc Ferme IN at the end of a Leg.

13.6 PARC FERMÉ:

Before the Start and between Legs, all vehicles must be placed to the Parc Fermé (for the night).

LOCATION: FŐTÉR, Szabadság Tér

13.7 FAULT START:

Vehicles, that cannot take the Start- in accordance with the TROB General Prescriptions point 41.1 can be pushed out from the timecontrol zone.

13.8 AVAILABILITY OF PARTICIPANTS

Participants who park their vehicles in the Parc Fermé upon passing the finish line, must remain available by phone (mobile) until the final classification have been posted.

13.9 ELECTRONIC START PROCEDURE AT THE START OF A SELECTIVE SECTION

The start of the selective section is happening based on an electric clock and lamp, connected to a false start alert system.

When the m/q arrives at the start line, the front of the m/q should be positioned behind a stick placed by the marshal to define the exact start position. One minute before the start time, but not before the car has stopped in its exact position, the marshal shall remove the stick and the competitor shall refer to the automatic countdown clock. Any subsequent change of the m/q's position until its start time is not permitted and will be reported to the Jury.

13.10 RECOINASSANCE

Reccoinassance of the entire Hungarian Baja route is forbidden.

14. SERVICEPARK

14.1 LOCATION:

GÁL GYULA SPORS HALL parking lot (with shower and toilet facility in the Sports Hall)

N 47°11'59.4132" E 18°8'48.7926"

8100. Várpalota, Fehérvári str. 9.

14.2 OTHER:

Entry will be permitted in the Service Park only showing the Service Plates provided by the Organizer. Accompanying team cars can enter only by purchasing a 10.000HUF sticker at the Administrative Checks.

Using a min 2x1m protector groundsheet under the racing vehicles is mandatory. 1pc at least 4kg walidated manual fire extinguisher is mandatory. Each service team has to ensure that after carrying out their activities on the site, they do not leave any pollutants.They will be checked by the environmental officer, and not complying will entail a 50.000HUF fine.

The Organizer calls the attention of the participants, that the Service Park is not guarded at night time!

15. PROTEST AND APPEALS

Protest fee: MAMS Cross-Country General Prescriptions

16. FINAL CHECKING

LOCATION: SUZUKI MÉSZÁROS, Gráblet Tó str.10

TIME: 07.08.2022. Immediate after arrival in the finish

17. RESULTS

17.1 PUBLICATION PROVISIONAL OVERALL CLASSIFICATION:

Digital Notice Board: Sportity, www.hungarianbaja.com and www.chronomoto.hu

17.3 PUBLICATION FINAL OFFICIAL CLASSIFICATION:

Digital Notice Board: Sportity, www.hungarianbaja.com and www.chronomoto.hu

18. PRIZES

18.1 PRIZE GIVING CEREMONY:

LOCATION: FŐTÉR, Szabadság Tér

TIME: 07.08.2022. 16:00

18.2 PRIZES:

Overall 1-3 - cup

Categories 1-3 - cup

LICENCE NR:

MAMS: MAMS/066/2022

EMN: 34/310

IMN Nr: 814/05

Appendix 1_Timetable



HUNGARIAN BAJA

MOTO

Leg 1								2022.08.05. FRIDAY / PÉNTEK		
Sunrise		5:29						20:17		Sunset
IE/TC	Location	SS Maximum Time	SS Km	Liasion Km	Total Km	Target Time	1st vehicle Due			
SS										
TC0	VÁRPALOTA Parc Ferme OUT						16:45			
TC1	Várpalota			3,33	3,33	0:10	16:55			
DSS 1	SSS1 START					0:05	17:00			
ASS 1	SSS1 FINISH	0:30	7,31		10,64	(0:05)	(17:05)			
	Várpalota					(Expected time of arrival)				
RZ 1	Refueling, Petrol Station, 14km,									
TC1A	Service IN			3,95	14,59	0:25	17:30			
SERVICE A										
TC1B	Service OUT			0,83	15,42	1:05	18:35			
TC1C	Regrouping IN			0,51	15,93	0:05	18:40			
REGROUPING										
TC1D	Regrouping OUT / Podium Start Ceremony						20:00			
TC1E	Parc Ferme IN / Early Check-IN is Authorised			0,15	16,08	0:30	20:30			
Day Total			7,31	8,77	16,08					
			45,46%	54,54%	100%					

Section 1



HUNGARIAN BAJA

MOTO

Leg 1		2022.08.06. SATURDAY / SZOMBAT					
Sunrise 5:30						20:15	Sunset
IE/TC	Location	SS Maximum Time	SS Km	Liasion Km	Total Km	Target Time	1st vehicle Due
TC1F	Parc Fermé OUT						8:00
TC2	Várpalota			2,63	2,63	0:10	8:10
DSS 2A	START					0:05	8:15
ASS 2A	FINISH	2:00	81,96		84,59	(0:55)	(9:10)
	Gyulafrátót						(Expected time of arrival)
Neutralization zone / FIM & MAMS REFUELING ALLOWED							
	Gyulafrátót			1,52	86,11	0:15	9:25
DSS 2B	START						9:25
ASS 2B	FINISH	1:40	56,08		142,19	(0:40)	(10:05)
	Újmajor						(Expected time of arrival)
RZ 2	Refueling, Petrol Station, 14km,						
TC2A	Service IN			33,01	175,20	0:50	10:55
SERVICE / SZERVIZ B							
TC2B	Service OUT			0,83	176,03	0:40	11:35
TC2C	Regrouping IN			0,51	176,54	0:05	11:40
REGROUPING							
TC2D	Regruping OUT						12:15
TC3	Várpalota			2,63	179,17	0:10	12:25
DSS 3A	START					0:05	12:30
ASS 3A	FINISH	2:00	81,96		261,13	(0:55)	(13:25)
	Gyulafrátót						(Expected time of arrival)
Neutralization zone / FIM & MAMS REFUELING ALLOWED							
	Gyulafrátót			1,52	262,65	0:15	13:40
DSS 3B	START						13:40
ASS 3B	FINISH	1:40	56,08		318,73	(0:40)	(14:20)
	Újmajor						(Expected time of arrival)
RZ 3	Refueling, Petrol Station, 14km,						
TC3A	Service IN			33,01	351,74	0:50	15:10
SERVICE / SZERVIZ C							
TC3B	Service OUT			0,83	352,57	1:20	16:30
TC3C	Parc Ferme IN / Early Check-IN is Authorised			0,51	353,08	0:05	16:35
Day Total			276,08	77,00	353,08		
			78,19%	21,81%	100%		



HUNGARIAN BAJA

MOTO

Leg 2		2022.08.07. SUNDAY / VASÁRNAP					
Sunrise 5:31		20:14 Sunset					
IE/TC SS	Location	SS Maximum Time	SS Km	Liasion Km	Total Km	Target Time	1st vehicle Due
TC3D	Parc Fermé OUT						8:00
TC4	Gyulafirátót			27,49	27,49	0:40	8:40
DSS 4	START					0:05	8:45
ASS 4	FINISH	1:40	66,26		93,75	(0:45)	(9:30)
	Várpalota					(Expected time of arrival)	
RZ 4	Refueling, Petrol Station, 14km,						
TC4A	Service IN			3,95	97,70	0:25	9:55
SERVICE / SZERVIZ D							
TC4B	Service OUT			0,83	98,53	0:40	10:35
TC4C	Regrouping IN			0,51	99,04	0:05	10:40
REGROUPING							
TC4D	Regruping OUT						11:15
TC5	Gyulafirátót			27,49	126,53	0:40	11:55
DSS 5	START					0:05	12:00
ASS 5	FINISH	1:40	66,26		192,79	(0:45)	(12:45)
	Várpalota					(Expected time of arrival)	
TC5C	Parc Ferme IN / Early Check-IN is Authorised			3,62	196,41	0:10	12:55
	Prize Giving and Podium Ceremony						16:00
Day Total			132,52	63,89	196,41		
			67,47%	32,53%	100%		

	SS km	Liasion km	Total km
Rally Total	415,91	149,66	565,57
	73,54%	26,46%	100%

Appendix 2_Competers Relation Officer



(ENG + HUN)
Mrs. Marianna MAGYAR KELEMENNÉ
+36 70 944 5148



(ENG + HUN)
Mr. István MÁTRAI
+36 20 417 6249

Estimated working plan:

Thursday 04. August	Admin check Scrutineering	08:00-19:00 10:00-21:00
Friday 05. August	Parc ferme Briefing / Start TC / Start Ceremony	12:00-15:00 16:00-22:00
Saturday 06. August	Parc ferme Service area Parc ferme Service area Parc ferme	08:00-10:00 11:00-13:00 13:00-14:00 14:00-16:00 17:00-19:00
Sunday 07. August	Parc ferme Service area PF/Parc ferme / Finish Ceremony	08:00-10:00 10:00-11:00 12:00-18:00

Appendix 3_ Instruction for the installing and use of the GPS Tracking System



MAIN SCREEN

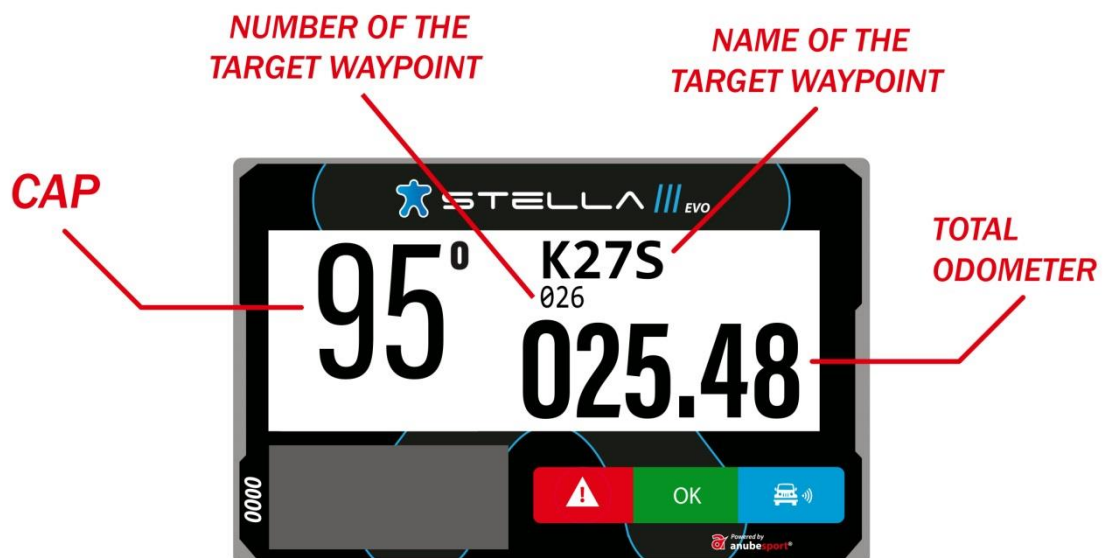

WAYPOINT PROXIMITY



SPEED ZONE

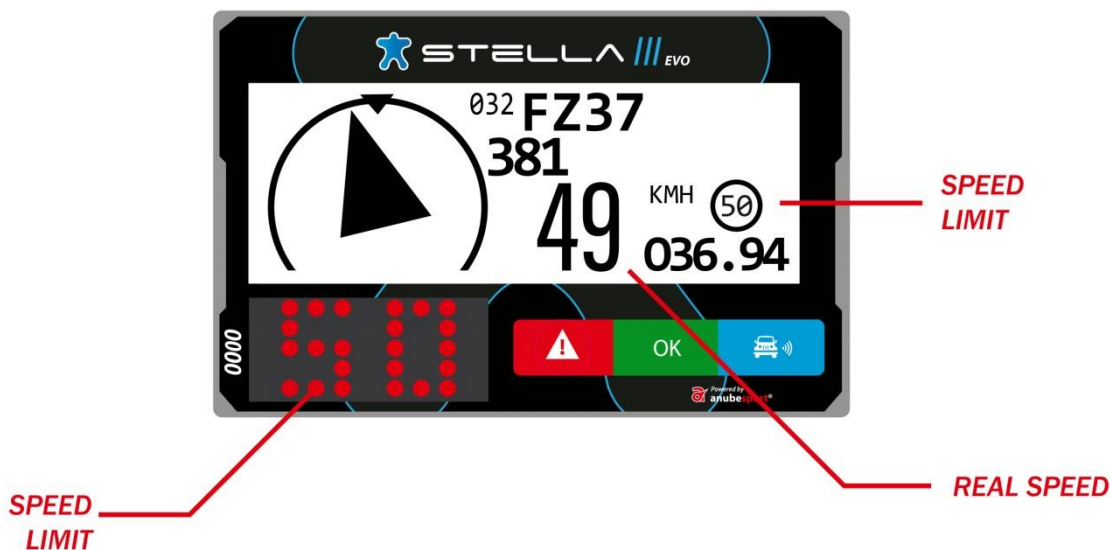

REQUEST MEDICAL ATTENTION IMMEDIATELY

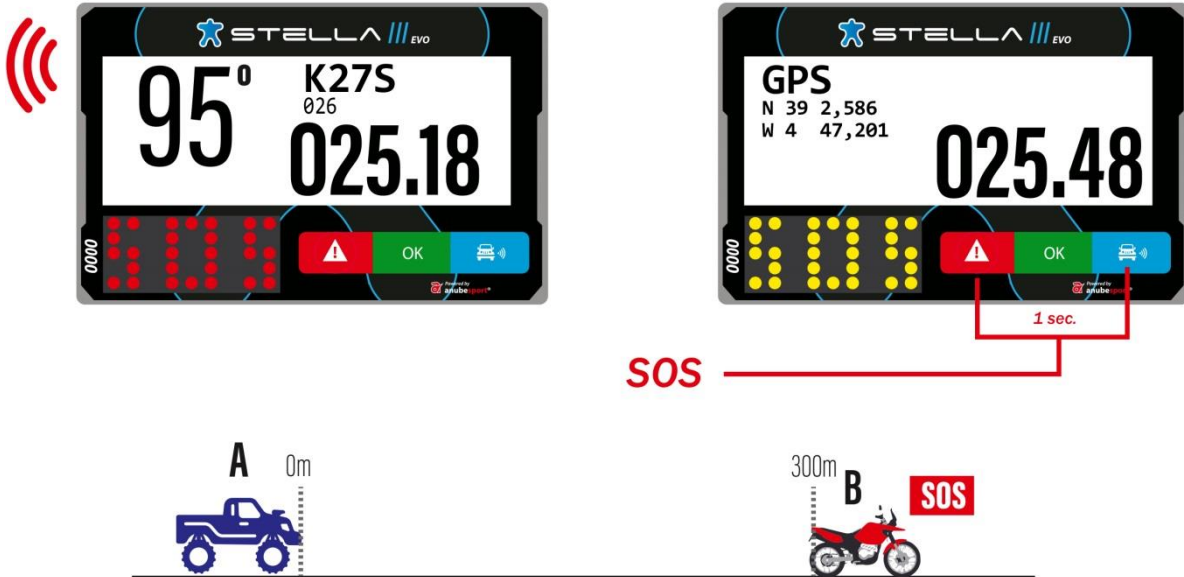

CAUTION VEHICLE STATIONARY

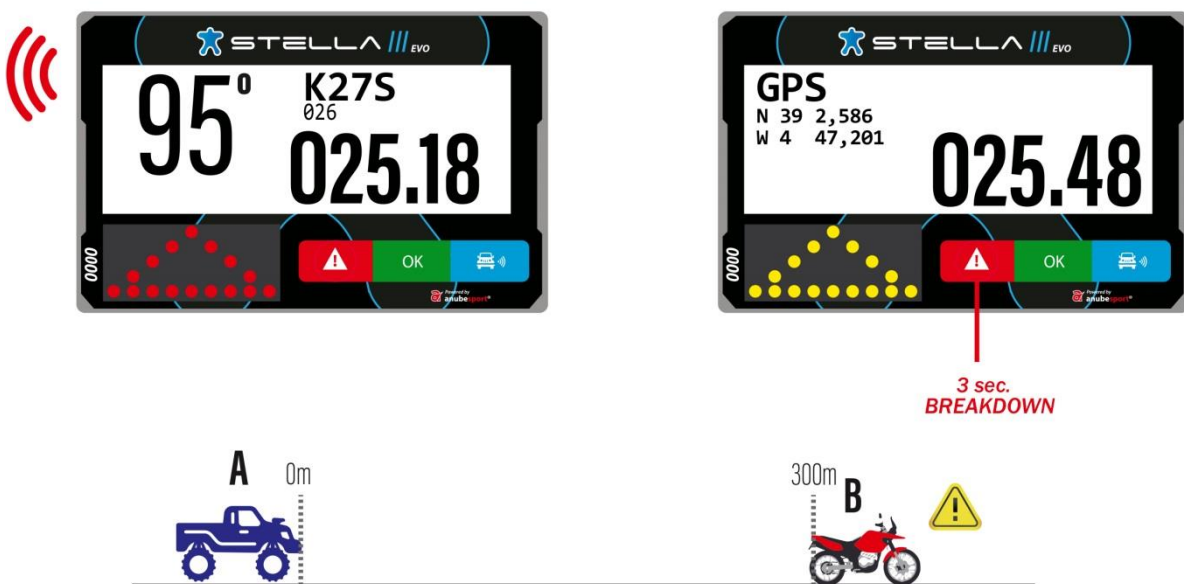

DANGER 3 !!!



Notification 300m before an area marked in the roadbook as "Danger 3"

OVERTAKING / BLUE FLAG



OVERTAKING / BLUE FLAG



STEADY



FLASHING



OVERTAKING / BLUE FLAG



FREE TO OVERTAKE



STEADY

PRESS THE BLUE BUTTON TO CONFIRM

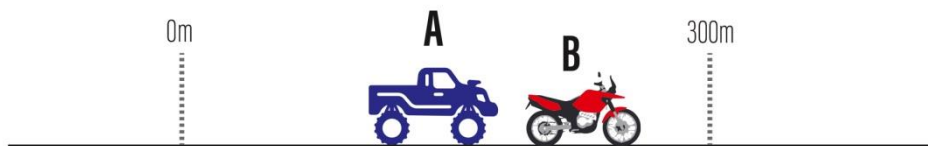

SPEED LIMIT

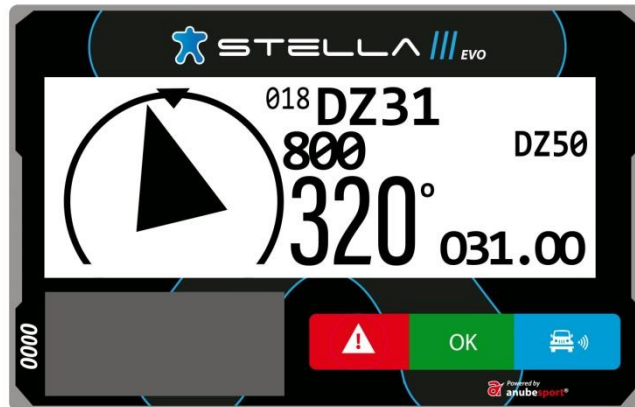

SPEED LIMIT

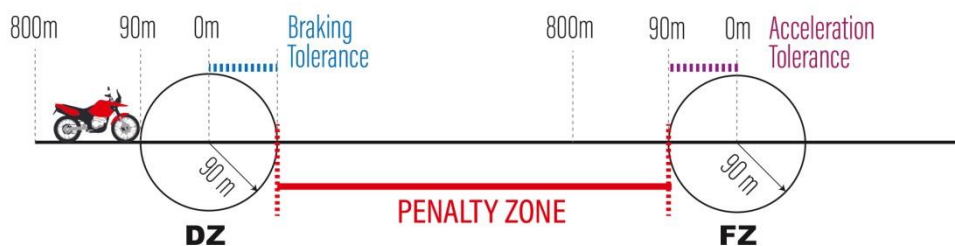
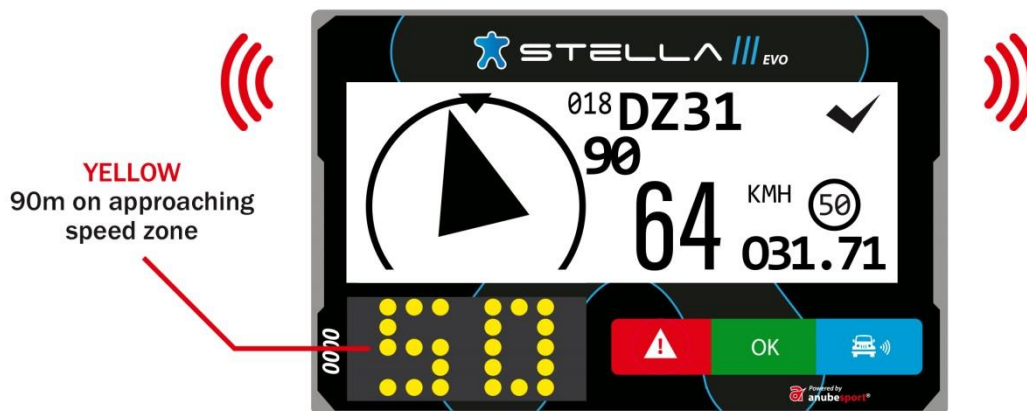

SPEED LIMIT



RED STEADY Inside of speed zone
RED FLASHING Overspeed

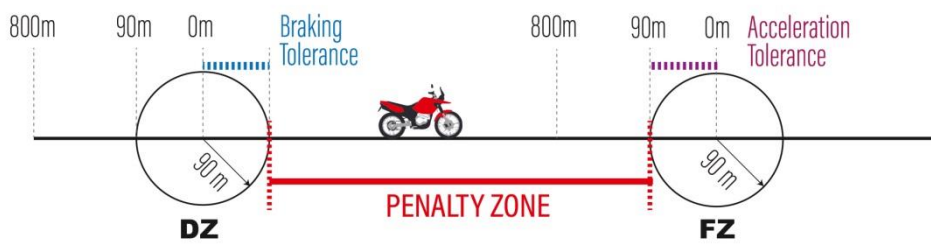

SPEED LIMIT



OFF end of speed zone

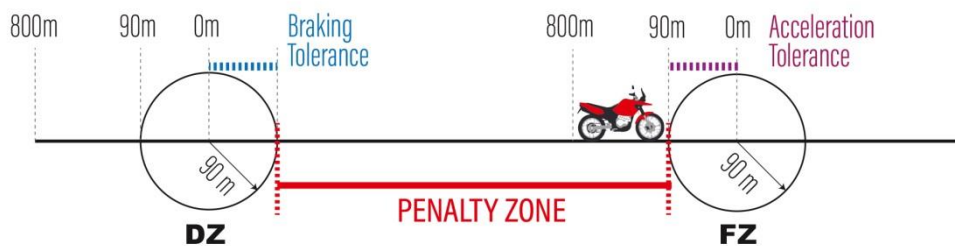
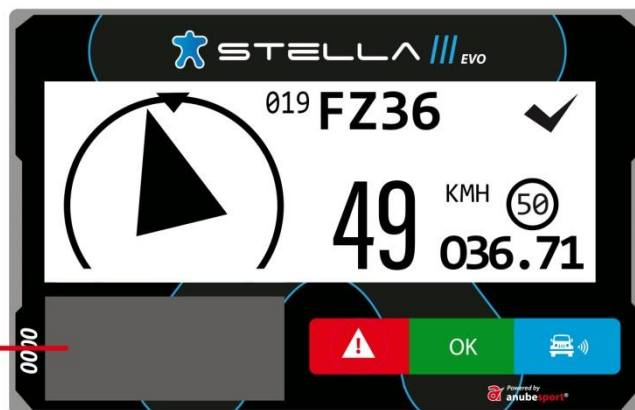

NEUTRALIZATION ZONE

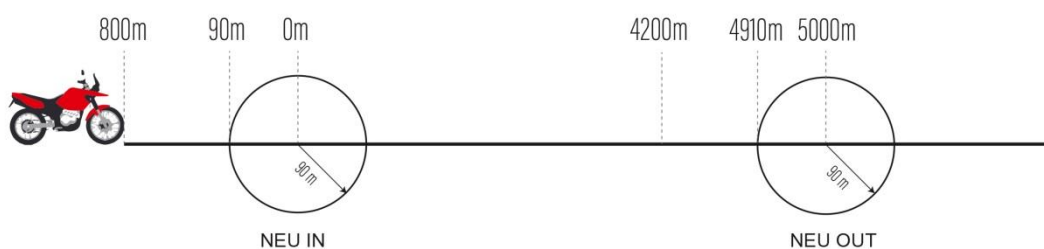

NEUTRALIZATION ZONE

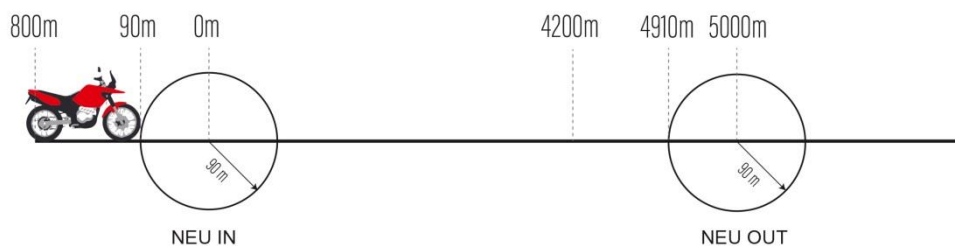

NEUTRALIZATION ZONE

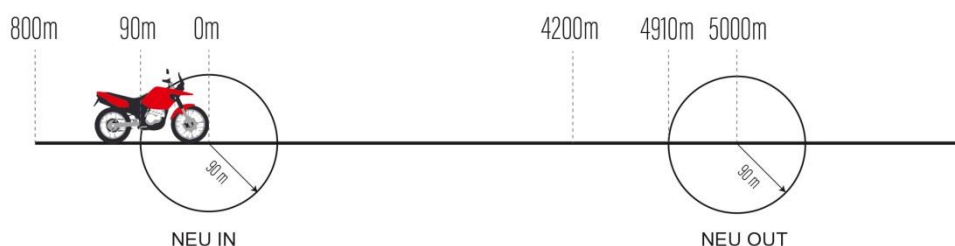

NEUTRALIZATION ZONE

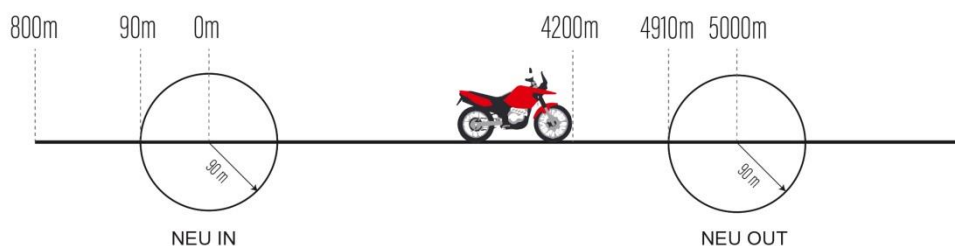
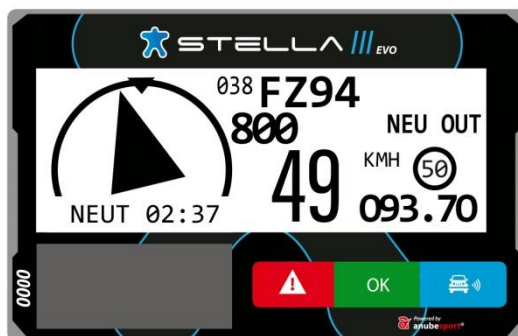

NEUTRALIZATION ZONE

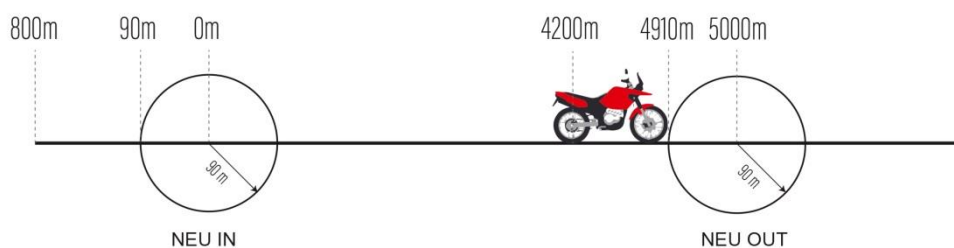

NEUTRALIZATION ZONE

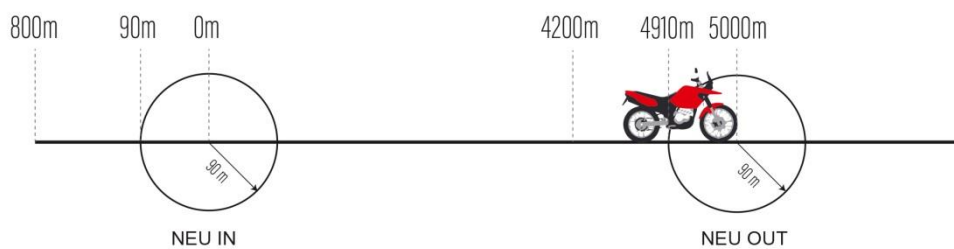

MESSAGES



WAYPOINTS LIST

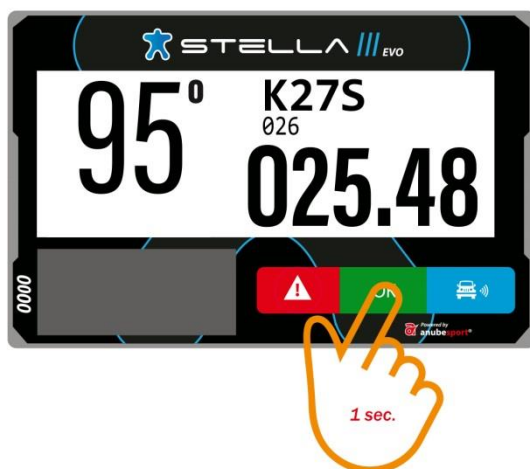

TOTAL ODOMETER RESET TO ZERO



OK

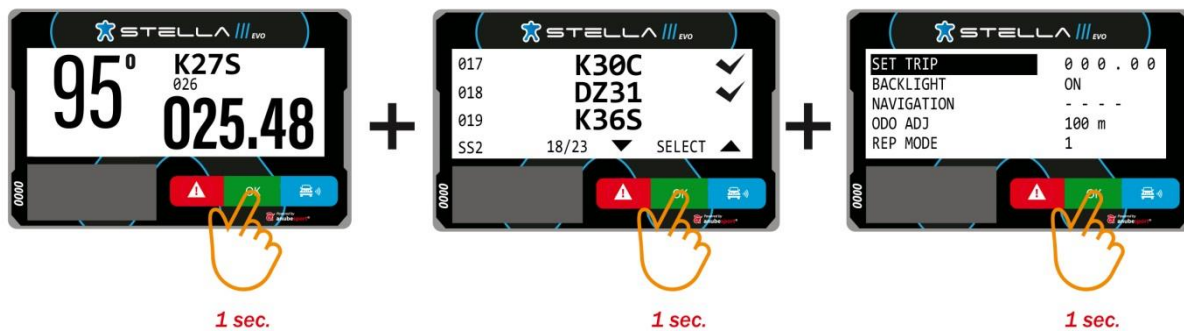

KIT COMPONENTS

60 €

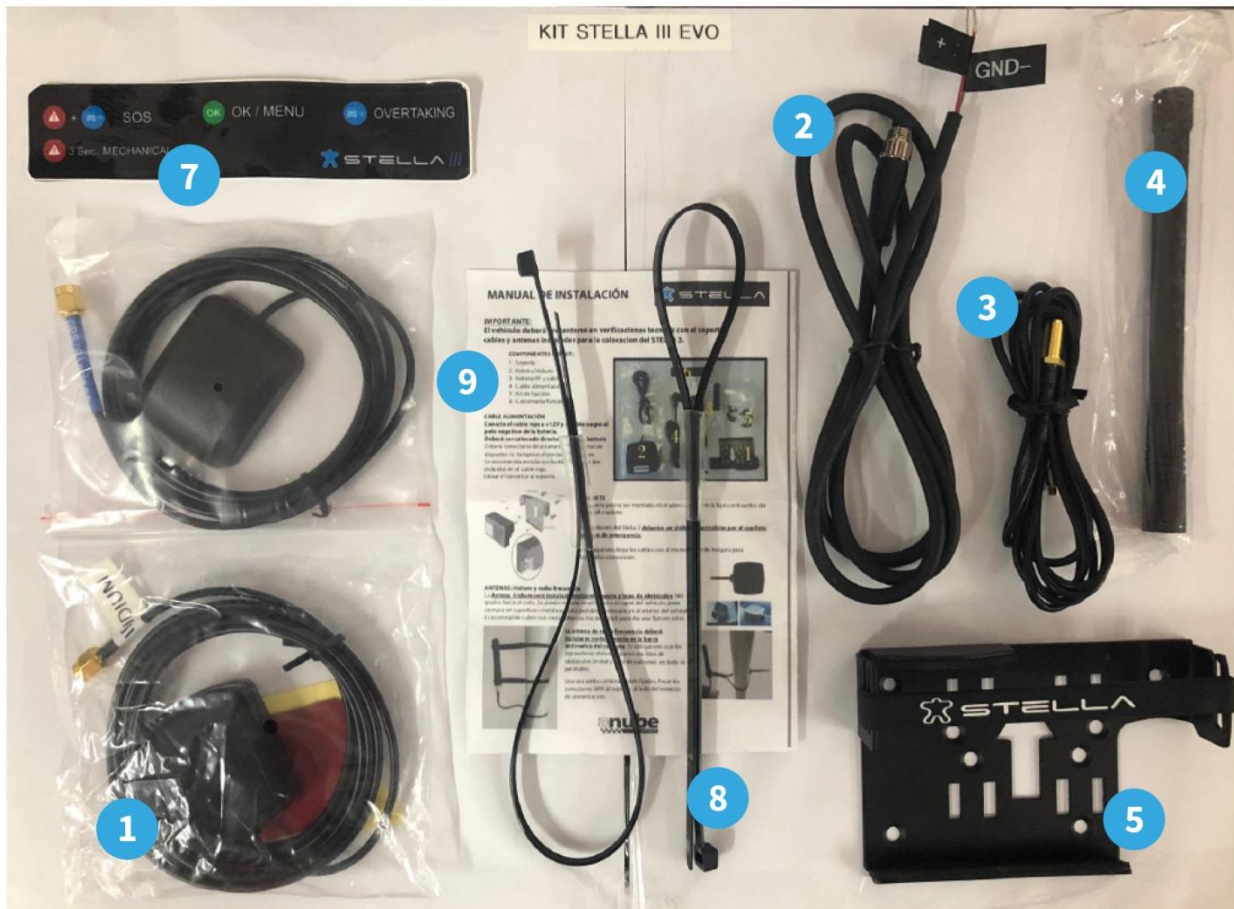

1. Iridium Antenna
2. Power Cord
3. RF Cord
4. RF Antenna
5. Base/Mount
6. GPS Antenna
7. Adhesive
8. Straps
9. User Manual

IMPORTANT

For the functional tests and verification, all vehicles must have gone through the installation of the mount, power cord, and antennas.

1. POWER CORD

- Connect the red wire to the positive end of the battery 12V(+), and the grey wire to the negative end (GRD). The power cord must be connected directly to the battery (without interruptions and without contact in the power supply).
- A 3A fuse (not included) should be connected to the red wire.
- Take the cord to the location in which the STELLA III EVO is to be installed. All other wires must be insulated, they cannot touch.



2. BASE/MOUNT

- Motorcycles and ATV: The mount can be attached to the handle bar or to a metal plaque close to the navigation system.
- Cars and UTV: The mount can be attached to the panel, or to the roll cage bars. STELLA III EVO buttons must be visible and accessible to the participant (pilot/navigator) even when they are sitting and with the seatbelts buckled.

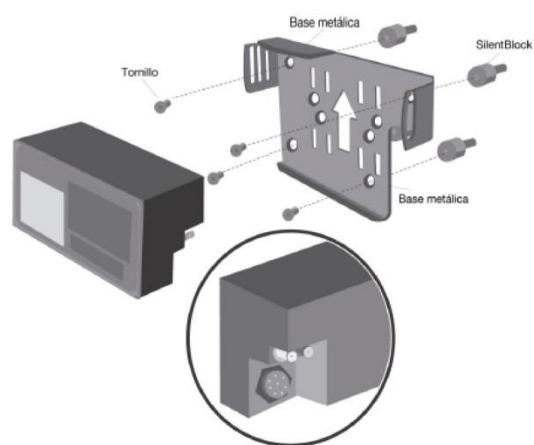

IMPORTANT

Leave the cords (antenna and battery) in place with at least 10 cm to spare for easy handling.

At least 5 cm of space behind the mount (bottom right corner) to allow space for power cord/connections.

3. GPS ANTENNA

The GPS antenna must be installed horizontally and without obstructions toward the sky. In cars and UTV, It can be mounted on the roof, the hood, or the dashboard. In motorcycles and ATV, attach to the mudguard. For additional firmness, it is recommended to cover it with adhesive tape (non metallic when mounting it to a metallic surface) and pull-up (when attached to soft or plastic parts).



4. ANTENNA IRIDIUM

The Iridium antenna must be installed horizontally and without obstructions toward the sky. In cars and UTV, It can be mounted on the roof, the hood, or the dashboard. In motorcycles and ATV, attach to the mudguard. For additional firmness, it is recommended to cover it with adhesive tape (non metallic when mounting it to a metallic surface) and pull-up (when attached to soft or plastic parts).



5. RF ANTENNA

The radio-frequency antenna must be installed vertically to the roll cage bars (cars and UTV) and the forks (motorcycles and ATV). It is mandatory to use separators (included in the kit) to avoid contact with metallic parts and the carbon fibre that surrounds it.

Once the antennas are mounted, take the SMA connection cords to the base/mount where the STELLA III EVO will be installed.



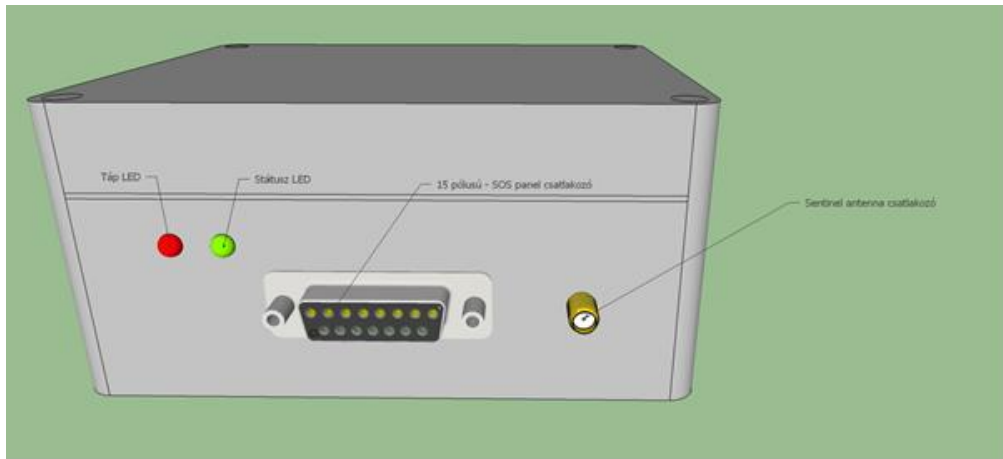

Pic. No. 1.: **GPS box**

Sizes: 115x90x55mm Weight: 340g + pipe clamps 110g

General operating principle of GPS measurements:

The GPS is an advanced positioning system for three-dimensional position determination, timing and velocity measurements can be carried out by land, sea or air. Accuracy is typically of the order of meters, but the environmental conditions can affect significantly. In the sky from the flat ground there are 7-25 satellites visible at the same time, of which for positioning at least three, for the height above sea level one additional satellite is necessary for determination. The GPS satellites are broadcasting at six frequencies. Each satellite broadcasts spread spectrum signal which may be "pseudo-random noise" called for.

The positioning is based on the theory of analytic geometric methods. The satellite positioning system is based on timing recycle distance measurement. Since we know the velocity of radio waves, and we know the date of issue and receipt of radio waves, can be determined based on the distance of the source of these. In the three-dimensional space knowing the exact measured distance from three known positions we are able to determine the position. Measuring the distance with other satellites we are able to improve this value.

Cause A significant distortion in the system can be caused by the effect of atmospheric to the radio waves. At the description of the calculations we assumed that to simply calculate with the distance = rate x time formula. This is true, but that the speed of radio waves are only constant in the vacuum pressure.

Evaluation of data

The evaluation of uploaded data can be determined inf two different ways.

Initial assessment of the competition supervision interface, real time data available online. This means the data that the device has been uploaded to the central database and downloaded online, analyzed by the supervisory program. The yet uploaded or not yet analyzed data will be carried over in the subsequent analysis. Not uploaded data case occurs when the device is in the absence of strenght of GSM signal, and can not upload data to the central database. In the case where the data is available online in the database, but local network is busy or the downloads has interrupted due to bad network relationship, then the analysis of loss data only partially can take place online.

Alternate method is retrospective data analysis. In this case, the data collected what has been received by a specified time interval sets the database to a file, and the data can be evaluated from point to point.

Overtaking signaling system function function

The device has a frequency of 433 MHz using radio module, which is broadcasting the data of an encoded in advance "bagpipe" and SOS functions corresponding sets of data, for the tools staying in range. The range distance can be greatly affected by ambient atmospheric conditions and terrain. The device has adjustable transmission power. This value is not possible adjustable during the race. Currently, the Overtaking signaling system function has two functions:

- "Toot" function, which indicates the overtaking intent of the Overtaking signaling system function equipped car up to 100m distance. Pressing the SOS button, placed in the box, a red LED indicates the start, which lasts for 5 seconds. In the event that the other device receives the sent signal, then this confirms to the sending device and the server uploads the signal, and at the same time, in the overtaken vehicle's SOS panel's LED will lit blue with a

beep sound (continuous), and in the overtaker's vehicle the LED color changes from red to blue light, no beep sound here. The indicator remains on the overtaken's vehicle for 10 seconds. Then, each signal is switched off until a next signal.

-Send SOS signal devices within range. This feature will be active if on the SOS panel, the SOS switch is turned on. Send the device continues the signal, until the SOS switch is turned on. In the case where a device receives the SOS signal, on the SOS panel the red and blue LED will blink, with a pulse (0.5 s) alarm signal, as long as it is still within range. This feature requires a power supply operation.

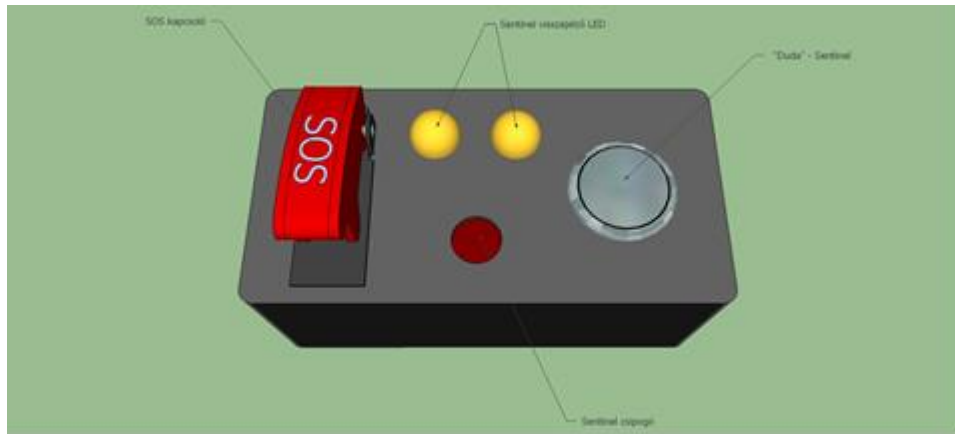

Pic. No. 2.: **SOS Panel** Sizes: 95x48x67mm Weight: 120 g

Tool installation

- SOS panel, Overtaking signaling system function antenna placement: Previously purchased SOS panel's red and black wires with the 2poled TMWS2T connector must be connected to the 5A fuse mating port (horizontal shoe positive, vertical shoe negative polarity), 15 poled connector's end has to be wired with the right B column. SOS panel should be placed on the dashboard in such a way that both the driver and the navigator can reach. The adhesive antenna supplied shall be affixed to the top right corner of the windshield horizontally, the end of the cable wired to the right-hand column B.

- Installing the device: The device received at the Administrative check must be connected to the previously purchased and installed SOS panel and Overtaking signaling system function antenna. The device must be fixed in the right column B with 2 clamps so that the device does not move and the visibility ensured.

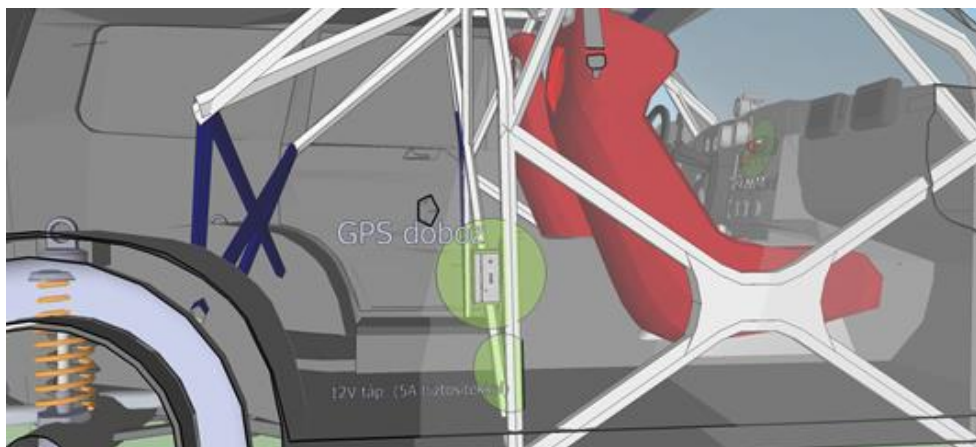

Pic. No. 3.: How to install 1.



Pic. No. 4.: How to install 2.4



Pic. No. 5.: How to install 3.4

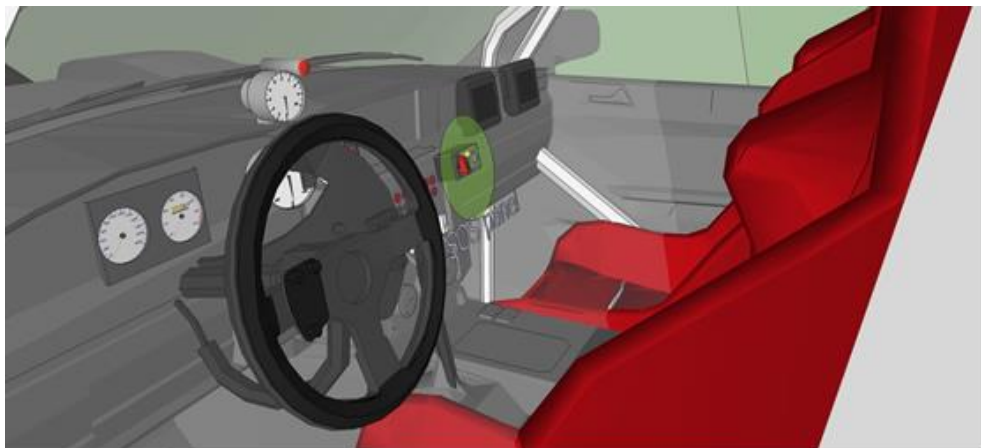

Pic. No. 6.: How to install 4.4

- To verify the functionality of the device will take place at the Technical Scrutineering .
- At the end of the race the device should be returned to the colleagues, where the deposit will be repayed. In case if the device has any problem, until identifying the problem, the competitor is entitled to the deposit only after a corresponding deduction.

More info: +36302413111 - Marton Zsolt